

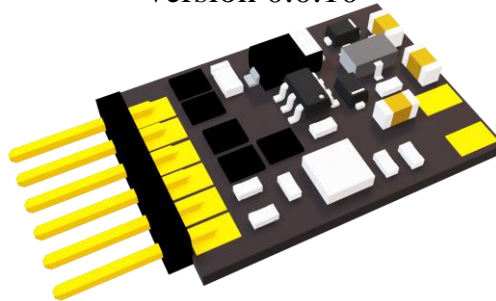

FD Micro Function Decoder

User Manual
– version 0.0.10 –



© Copyright 2023 Tehnologic Ltd. All rights reserved

No part of this publication may be reproduced or transmitted in any form or by any means, electronic or mechanical, including photocopying, without the written permission of Tehnologic Ltd.

by **TEHNO
LOGISTIC**



Subject to technical modification



Please read this manual carefully before proceeding with the product installation!!! Even if our products are very robust, incorrect wiring and/or usage may damage the module!

Normal operation of the product requires that the defined technical parameters to be met.

During storage, installation and operation keep the product in dry environment and away of direct sunshine.

A soldering tool may be necessary for the installation and/or mounting of the devices, which requires special care.

When installing the product, if it is not protected with heat shrinkable tube, make sure that no side of the board is in contact with conductive materials.



Contents

1. Important information	5
2. Abbreviations	6
3. User manual contents	7
4. Main features	8
5. Technical specifications	9
6. General description of FD Micro decoders	10
7. Decoder installation	16
8. Setting up the decoder	20
9. Decoder address	21
9.1. Consist address	22
10. Resetting the decoder	23
11. Function Mapping	23
11.1. Standard Function Mapping	23
11.2. Extended Function Mapping	24
12. Effects	27
13. Multiple protocol operation (analog and digital operation)	37



14. Secondary address (decoder lock)	38
15. Bidirectional communication (RailCom)	40
16. Special functions	41
17. SUSI	42
17.1. Programming SUSI modules	42
18. Using a power pack or external capacitors	44
18.1. SPP (with supercapacitor)	44
18.2. Buffer capacitor	46
19. Firmware update	48
20. User data	49
21. Other functions	49
22. Accessories	50
23. Technical support	50
24. The decoder CV table	51



1. Important information



Please read this first chapter

- The FD Micro decoders are designed exclusively for use in model trains. Any other use is forbidden.
- Any connection must be made without the connected power supply. Please make sure that during installation, the locomotive is not powered, not even accidentally.
- Avoid applying blows or mechanical pressure on the decoder.
- Do not remove the heat shrink tube from the decoder (on models fitted with a protective sleeve).
- Ensure that neither the FD Micro decoder nor the unused wires do not come into electrical contact with the locomotive chassis (short-circuit risk). Insulate the ends of any unused wires.
- Do not solder extension cables on the decoder circuit board except in cases strictly necessary (connections to sound modules, power packs).
- It is forbidden to wrap the decoder in an insulating tape, as this may cause overheating.
- Observe the wiring of the decoder and any external components as recommended in this manual. Wrong wiring / connection can cause damage to the FD Micro decoder.
- Make sure that there are no wires trapped by the locomotive transmission system when reassembling it.
- Any power source used must be protected by fuse or electronics to avoid any danger that may arise in a short circuit. Use only transformers or power supplies specially designed for electric trains.
- Do not let the FD Micro decoders to be used by unattended children. The FD Micro decoders are not a toy.
- Do not use FD Micro decoders in wet environments



2. Abbreviations

DCC	-	Digital Command Control
DC	-	Direct Current
NMRA	-	National Model Railroad Association
CV	-	Configuration Variable
PT	-	Programming Track
PoM	-	Programming On the Main
MSB	-	Most Significant Byte (or Bit)
LSB	-	Least Significant Byte (or Bit)
FL	-	Front Light
RL	-	Rear Light
SPP	-	Smart Power Pack
NC	-	Not connected



3. User manual contents

We thank you for purchasing a FD Micro function decoder. We hope it will add an extra enjoyment to your model train experience.

This manual is divided into several chapters, which show you step-by-step how to install and customize a FD Micro function decoder.

- Chapter 4 and 5 provide an overview of the features and parameters of the decoders.
- Chapter 6 contains the general description of the decoders.
- Chapter 7 describes the installation of decoders in locomotives. Please familiarize yourself with the type of interface existing in the locomotive before going through this chapter. The FD Micro decoders can be operated with most commercially available control systems for electric train models.
- Chapters 8 ÷ 21 explains configurable parameters, and how to customize them.
- Chapters 22 ÷ 23 contains information related to other products and technical support
- Chapter 24 contains the table with all the available CVs of the decoder.



4. Main features

- NMRA compliant Generic DCC mobile function decoder (no motor drive capability)
- PT or PoM programming modes
- Operation even in analog mode (DC), with configurable active functions
- Short (1-127) and long (1-10239) configurable addresses
- 14, 28/128 speed steps
- Two power outputs with integrated current limiting resistor (active low outputs, with load connected between output and common plus)
- Four logic level outputs (for LEDs or other digital output, active high outputs, with low power consumers connected between output and ground)
- Multiple effects available for each output
- Output Mapping to functions F0, F1-F28
- Bidirectional communication, RAILCOM©
- SUSI© interface available on AUX3, AUX4
- Outputs configurable for Smart Power Pack (SPP ©) control
- Upgradable software via the programmer, even with the decoder assembled in the locomotive
- Reduced dimensions make it usable in Z, N, TT, H0, H0e scale models



5. Technical specifications

- Supply voltage range: 4 ÷ 24Vdc or standard DCC track signal
- Withstand for short time to 38Vdc
- Stand by current (all outputs off): < 10 mA
- Maximum current for each logical output: 5 mA
- Decoder size is as in Table 1: FD Micro variants
- Weight: 4÷6 g
- Protection class: IP00
- Operating temperature: 0 °C ÷ +60 °C
- Storage temperature: -20 °C ÷ +60 °C
- Humidity: max 85 % non-condensing



6. General description of FD Micro decoders

The FD Micro function decoders are designed to be used in Z, N, TT, H0, H0e scale models. The different models are differentiated by the connector type and/or number of soldered wires. From functional and programming point of view they are identical.

The table below contains the FD Micro decoder models with corresponding ordering code and size .

The drawings show the real wire colors (according to NMRA standard), and they are 100mm \pm 5% long.

Table 1: FD Micro variants

Decoder name	Connector - wires	tOm order code	Dimensions without connector
FD MICRO 6P	NEM651 straight	02010106	13x9,3x2,5mm
FD MICRO 6P90	NEM651 in angle	02010107	13x9,3x2,5mm
FD MICRO 4W6P	NEM651 + 4 Wires	02010108	13x9,3x2,5mm
FD MICRO 5W	5 Wires	02010109	13x9,3x2,5mm
FD MICRO 5W8P	NEM652 + 5 Wires	02010110	13x9,3x2,5mm
FD MICRO 10WN18	NEXT18 + 10 Wires	02010111	13x9,3x2,5mm
FD MICRO 2W	2 Wires	02010112	13x9,3x2,5mm



Figure 1: FD MICRO top view pinout

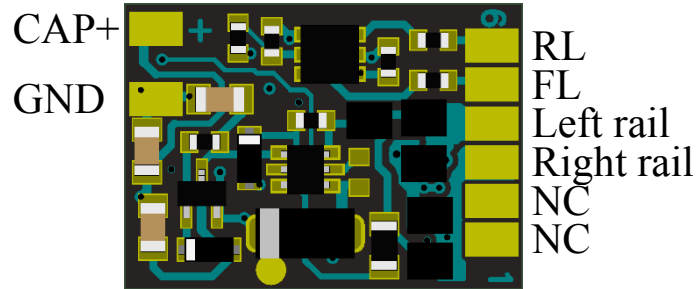

Figure 2: FD MICRO bottom view pinout

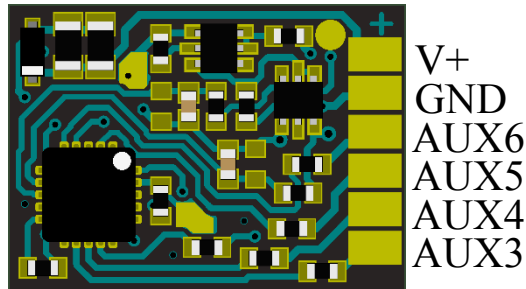



Figure 3: FD MICRO 6P

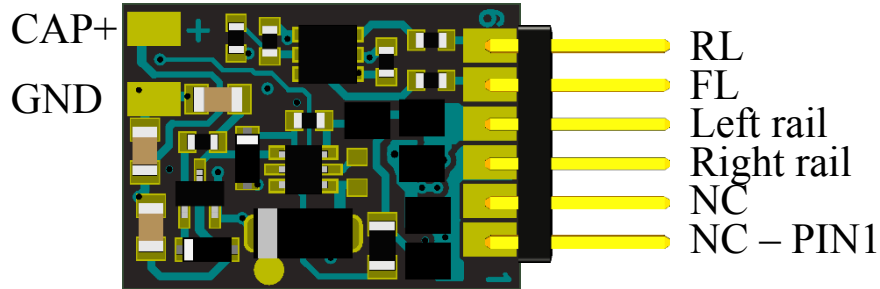

Figure 4: FD MICRO 6P90

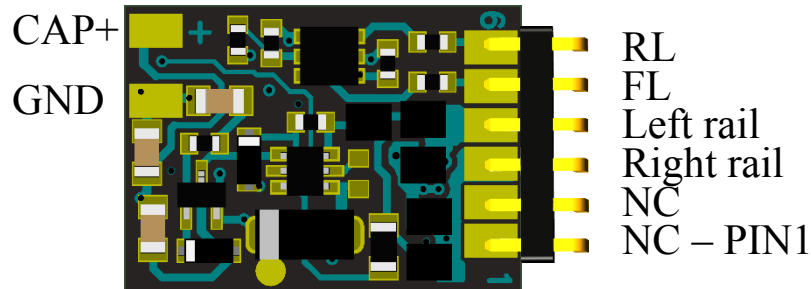



Figure 5: FD MICRO 4W6P

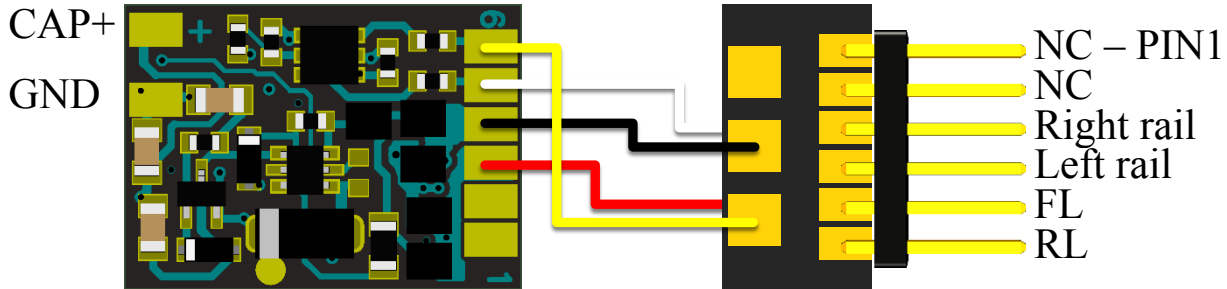

Figure 6: FD MICRO 5W

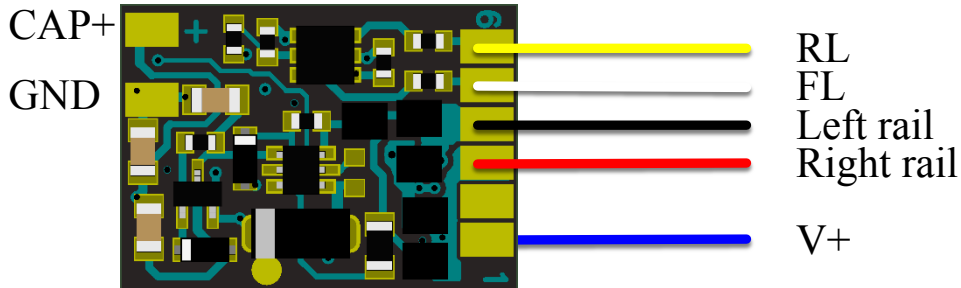



Figure 7: FD MICRO 5W8P

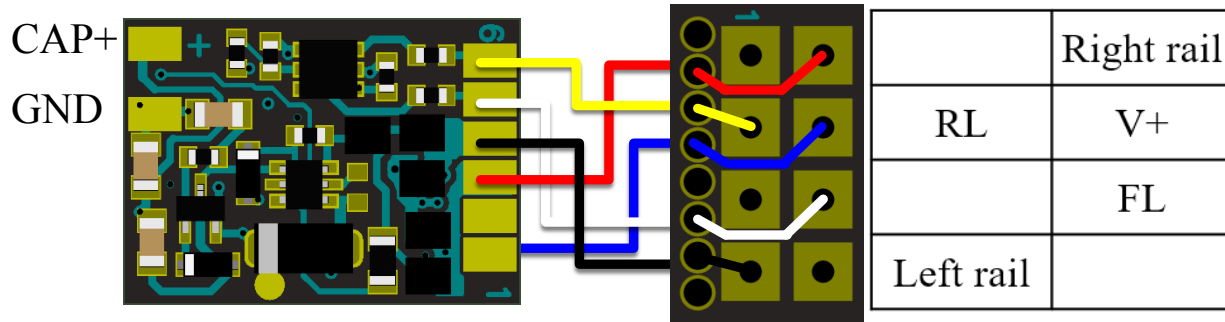

Figure 8: FD MICRO 2W

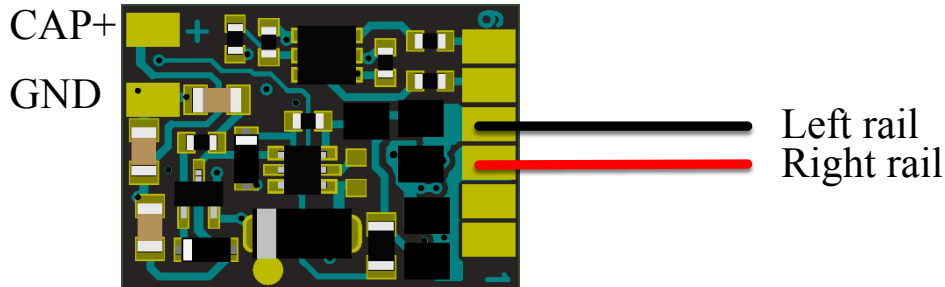



Figure 9: FD MICRO 10WN18 connection diagram

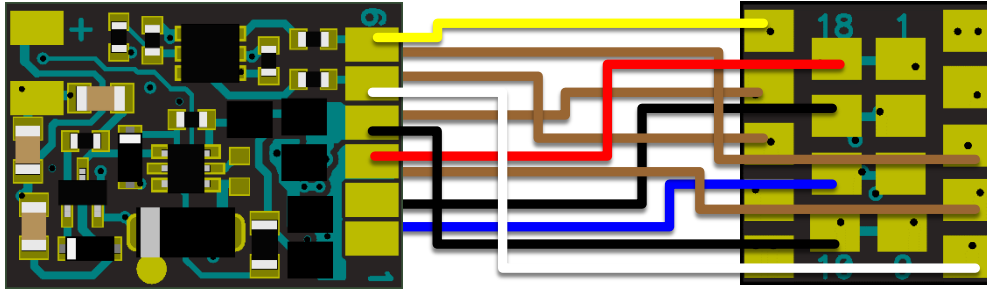
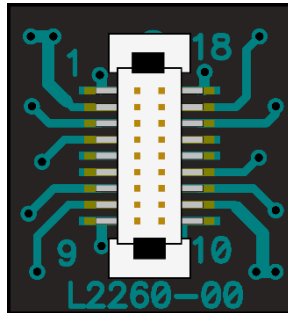
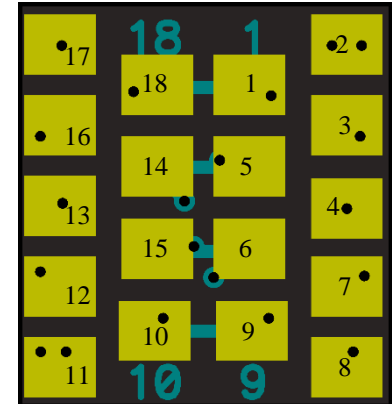

Figure 10: FD MICRO 10WN18 connector pinout

Name	Pin
Right Rail	1
NC	2
NC	3
AUX3/SUSI-CLK	4
GND	5
V+	6
AUX6	7
FL	8
Track Left	9



Pin	Name
18	Right Rail
17	RL
16	AUX5
15	V+
14	GND
13	AUX4/SUSI-DATA
12	NC
11	NC
10	Track Left





7. Decoder installation

Before installing a digital decoder, especially in older used models, it is a good idea to make sure that the model is operating properly in DC. To do this, perform the following operations:

- Clean the wheels and the current collectors
- Check the transmission system, if necessary, clean and lubricate the axes and the sprockets.
- If the locomotive is equipped with light bulbs, check if they are rated to 16V. Replace them if necessary.

In the case of locomotives prepared for digitization, the installation of the decoders equipped with the standard connectors (NEXT18, NEM651, NEM652) is done by extracting the dummy module for analog operation from the connector on the motherboard. Insert the decoder in the released connector by paying attention to the key (INDEX) or follow the instructions received with the locomotive.

The NEXT18, NEM651 and NEM652 decoders can be inserted in wrong position (180° rotated). None of the decoders will get defective, but they will malfunction or not function at all as shown below:

- NEXT18 – Will work but directional lights will be reversed
- NEM651 – Will not work at all
- NEM652 – The directional lights will not work



In the DC locomotives that are not prepared for digitization, a wired decoder (which has only connection wires) must be chosen and installed. The wires are color coded (as in the NMRA standard), the connections will be as shown in the Figure 11: Connecting the FD Micro.



For FL and RL the common will be connected to V+. For AUX3 ... AUX6 the common will be connected to GND. These connections are available in standard connector pins, wires, or soldering pads, as illustrated in General description of FD Micro decoders.



The Light Emitting Diodes (LED) are polarity sensitive. Connecting them in the wrong way will not damage either the decoder or the LED but they will not light



Figure 11: Connecting the FD Micro

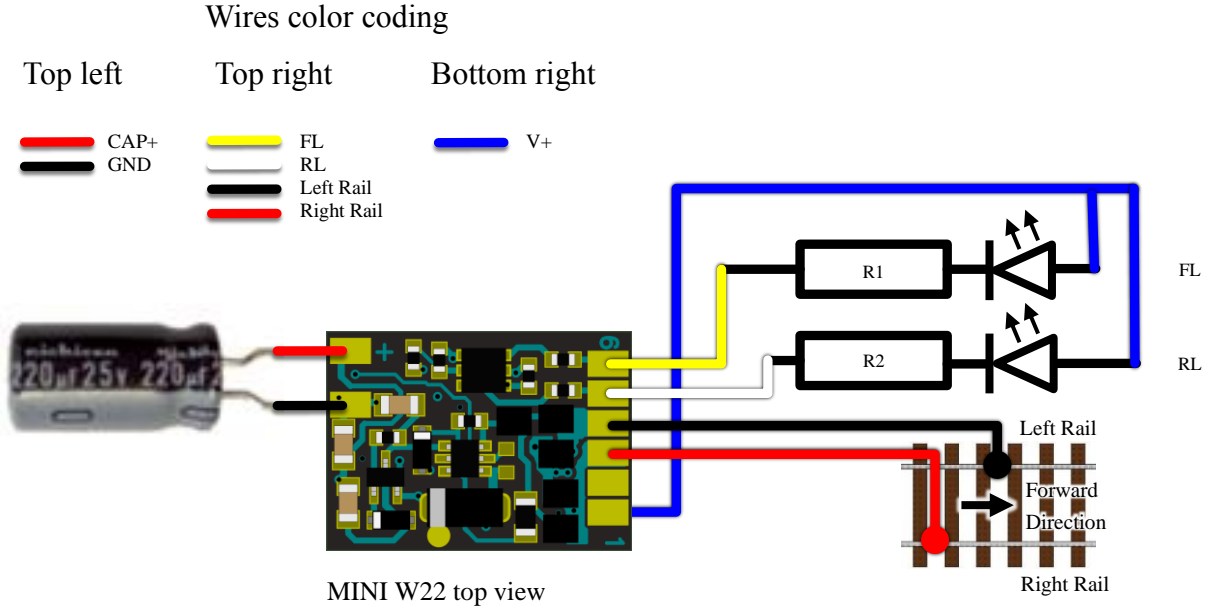







Note:

1. The resistors (R1 and R2) value should be between 470Ω and 10kΩ.
2. No resistors are needed if bulbs are used for FL and RL



Figure 12: Connecting the FD Micro (cont.)

Wires color coding

-  AUX3
-  AUX4
-  AUX5
-  AUX6
-  GND
-  V+

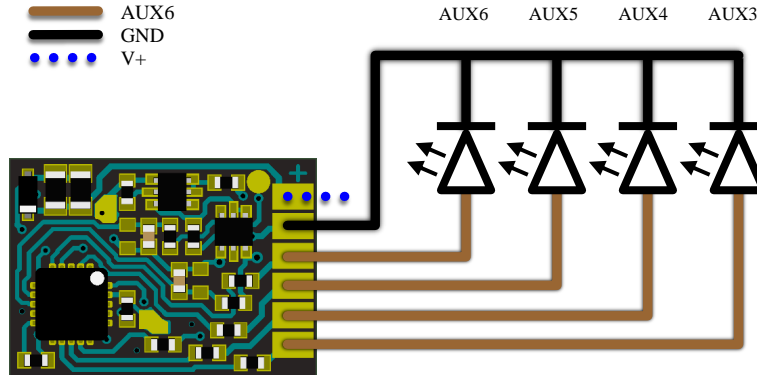

MINI W22 bottom view

Note:

AUX3-AUX6 are low current outputs so no resistors are needed for the LED's.



8. Setting up the decoder

Before connecting to the digital Command Station please make sure that:

- All connections were made in the right way
- There are no short circuits or loose/poor connections
- The wiring is not touching moving parts

If the decoder that is to be programmed is already installed in a locomotive, it is recommended to power it on placed on a programming track, assuring that it is the only one connected.

The first action after powering on is to perform a reset (write any value but not 128 in CV8) to make sure that factory default values are loaded and to set the desired new address in CV1. The decoder comes with default address 3 that can be changed also to extended address (see Decoder address).



9. Decoder address

The FD Micro supports either short address ($1 \div 127$) or long address ($1 \div 10239$). The factory default address is short (CV29 factory default value is 10 so bit 5 = “0”) and the address is 3 (CV1 = 3).

The short decoder address is stored in CV1 and can be changed with the Command Station.

To change the decoder address to long format, set Bit 5 of CV29 to “1”. In this way the decoder will have the long address stored in CV17 and CV18.

The long addresses will be calculated with the following algorithm (in our example we will consider the long address 2000)

- Divide the desired long address with 256 (in our example $2000 / 256 = 7$, remaining = 208)
- Add 192 to the result and program it in CV17 ($7 + 192 = 199$; program the value of 199 in CV17)
- Program the value of the remaining of the division in CV18 (program the value of 208 in CV18)

Program CV 29 as the last operation, after the long address is stored in CV17 and CV18. After programming the 3 CVs as described above, the decoder can be accessed with the address 2000. Change bit 5 of CV29 to “0” to switch back to short address mode.



When a value is written in CV1, the consist address will be automatically cleared, and the extended address will be automatically disabled!



9.1. Consist address

The Function Decoders support the Advanced Consist functions. To activate this feature, the consist address must be set in CV19. When the content of CV19 is different from 0, the decoder will perform functions that are defined in CV21 and CV22 if they are transmitted to the consist address. All other functions will be performed while they are sent to the base address (defined in CV1 or CV17/CV18).

Functions in CV21(F8-F1), CV22(F12-F9, F0R, F0F) will not be performed if they are transmitted to the base address. For bit value “0” the function will only be enabled with the individual address, for value 1 the function will only be enabled with the consist address (see The decoder CV table).

Example: if we want to use F0F, F0R, F3 and F4 with consist address, the following values are to be written in CV21 = 12 (00001100) and in CV22 = 3 (00000011).

Speed and direction commands will be sent to all decoders within the same consist. In this way the headlights (of locomotives) and taillight of carriages can be turned on and off, based on the direction commands sent to the consist addresses, while the interior lights in different carriages can be turned on and off based on their individual base addresses.



Only functions F0, F1÷F12 can be used in consist mode. The speed steps setting in CV29 must match the speed step setting of the Command Station for both base and consist addresses.



10. Resetting the decoder

The default Configuration variables (CVs) values can be found in The decoder CV table. Most of the values can be changed by the user. Programming any value in CV8 will reset the Function Decoder to factory default CVs.

11. Function Mapping

The assignment between Functions and Outputs is known as Function Mapping. The Function Decoder supports Standard and Extended Function Mapping, and this can be changed with CV96 as follows: CV96 = 1 (default) means Standard Function Mapping, CV96 = 6 means Extended Function Mapping.

11.1. Standard Function Mapping

The FD Micro Function Decoder is configured by default to use a Standard Function Mapping. Each Function (from F0 to F28) can be used to activate any combination of Outputs. The configuration is performed by programming the corresponding bits in CV33÷CV62.

The decoder has a total of 6 outputs and each Function Mapping requires one CV. For the light function (F0) the mapping can be defined separately for each travel direction so 2 CVs are used. The other functions (F1÷F28) are not travel direction dependent so one CV is used. One bit value is assigned in the CV that maps the function of each decoder board physical output (exception is F0 with 2 CVs). Bit0 correspond to FL and bit1 to RL and so on.



If the function activates the corresponding physical output, the decimal values for each bit (powers of 2) will be considered. If the function does not use the corresponding output, the bit value will be set to zero. The mapping CV will be programmed with the sum of the decimal values of each active output.

Example: if you want to use function F2 to activate FL, CV36 will be used for mapping (which configures/maps F2). For this bit0 of CV36 must be set to “1” (binary) so the decimal value will be 1. F2 will activate also RL when bit1 of CV36 will be set to “1” (binary), decimal value will be 2. If both outputs are ON then CV36 will have a decimal value of 3 ($3 = 1 + 2$).

11.2. Extended Function Mapping

To use Extended Function Mapping in CV96 must be written the value 6. In this mode CV33÷CV62 value are ignored. The Extended Function Mapping uses groups of 16 CVs for each output, from which not all are use (some CVs are reserved for further use).

Table 2 shows the byte structure.

Table 2

Bit7	Bit6	Bit5	Bit4	Bit3	Bit2	Bit1	Bit0
Reverse	Forward	Function number					



In this mode each output can be turned on with two different functions stored in CV120÷CV121 for FL and CV136÷CV137 for RL. Bit6 and bit7 of these CVs is controlling the direction dependency of the functions. Setting bit7 to binary “1” (which is equivalent with adding decimal 128 to the CV value), the corresponding function will set the output in reverse direction only. Setting bit6 to binary “1” (which is equivalent with adding decimal 64 to the CV value), the corresponding function will set the output in forward direction only. Setting both bits (6&7) to binary 1, the corresponding output will be always turned on independent to direction and function state.

The mapping mode is described in Table 3.

Examples:

- If FL must be turned on with F0 in forward direction only, CV120 or CV121 value must be $0 + 64 = 64$ (decimal).
- If RL must be turned on with F2 in reverse direction only, CV136 or CV137 value must be $2 + 128 = 130$ (decimal).
- An unused CV will have the value 63, which has no effect as in Table 3.

With the function configured in CV122 (for FL) and CV138 (for RL), the corresponding output activation can be disabled. The usage is almost similar with the one described in Table 3 with the difference that the effect is opposite, the output will be turned off instead of being turned on.

Example:

- if the value $68 = 64 + 4$ is written in CV122, function F4 will disable FL in forward direction only.



Table 3

CV120,121,136,137 value	Description
n ($n \leq 28$)	Function number “n” will turn on the corresponding output in forward and reverse direction
$n + 128$ ($n \leq 28$)	Function number “n” will turn on the corresponding output in reverse direction only
$n + 64$ ($n \leq 28$)	Function number “n” will turn on the corresponding output in forward direction only
$28 < n < 64$	settings have no effect
$n + 192$ ($n \leq 28$) ($192 = 128 + 64$)	output always turned on



12. Effects

The effects are defined separately for each output by writing the effect number in the corresponding CV: CV124 for FL and CV140 for RL and so on.

In this chapter we will use the following abbreviations:

- TSD = Total Sequence Duration
- P-ON = Light Pulse ON Duration
- P-OFF = Light Pulse OFF Duration
- N = Number of pulses/sequences
- PWM = Pulse Width Modulation

The effects list can be found in Table 4 and description of the effects with some examples will follow.



FD Micro Function Decoder

User Manual for FW 1.2.28

Version 0.0.10

Table 4

Effect number	Effect description	Note
0	Lights switch ON and OFF with no effect	
1	Lights switch ON and OFF with fade effect	See CV 112, CV113
2	Lights switch ON with specific Neon flicker effect	See CV114, CV116
3	Flicker effect, continues slow flickering (visible if light intensity > 16)	See CV123, CV139
4	Defective neon effect (Flickering)	
5	Output used for SPP	
8	Symmetrical flashing, with blinking period TSD, instant on/off	See CV125, CV141
9*	Symmetrical flashing with fade IN/OUT	See CV125, CV141, CV123, CV139
10	Asymmetrical flashing 1/4-ON; 3/4-OFF	See CV125, CV141
11*	Asymmetrical flashing 1/4-ON; 3/4-OFF with fade IN/OUT	See CV125, CV141, CV123, CV139
12	Asymmetrical flashing 3/4-ON; 1/4-OFF	See CV125, CV141
13*	Asymmetrical flashing 3/4-ON; 1/4-OFF with fade IN/OUT	See CV125, CV141, CV123, CV139
14	Custom blinking: TSD, P-ON, P-OFF and N can be defined independently following certain constrictions described below	FL CV124÷CV126 RL CV140÷CV144
15	Custom blinking with random number of blinks	FL CV124÷CV126 RL CV140÷CV144

*See Figure 15



PWM (light intensity) setting is affecting all the effects. For the effects that have fade/dimming (the ones with * in the Table 4) the light intensity setting will also affect the effect behavior. Effect 0 means that the output will be switched on and off instantly.

Effects 1 to 4 are non-repetitive effects, meaning that that the lights must be turned on and off manually by the user. For effects 1 to 3 the effect behavior can be changed with the CVs mentioned in the “Note” column.

All the effects starting with number 8 are repetitive and the effect sequence duration can be set by the user in certain limits. For these effects there are some rules that must be followed to make sure that the effect behavior is as intended.

Certain settings will affect all outputs and they are in CV112÷CV117 and other settings are set individually for each output. CV123÷CV128 are for FL and CV139÷CV144 are for RL. Table 5 is showing the available settings and ranges.



FD Micro Function Decoder

User Manual for FW 1.2.28

Version 0.0.10

Table 5

Name	CV# for FL	CV# for RL	Value range*
FadeIN Effect, 8ms steps (default 200ms)	112		1÷127
FadeOUT Effect, in 8ms steps (default 120ms)	113		1÷127
Fluorescent Tube Start, Blinking Delay 1÷8	114		0÷7
Random Time Period, 1s÷255s	115		1÷255
Flicker Period: Fast-Slow 0÷7	116		0÷7
Defective Neon effect repetition time, 0=fast, 7=slow	117		0÷7
Light intensity, 0=OFF, 255=maximum	123	139	0÷255
Effect number (see Table 4)	124	140	0÷4, 8÷15
Total sequence duration (TSD)	125	141	4÷255
Light Pulse ON duration (P-ON)	126	142	1÷252
Light Pulse OFF duration (P-OFF)	127	143	1÷252
Number of pulses/sequence (N)	128	144	1÷63

*See below range details and examples.



Technically all the CVs can accept value ranges from 0 to 255, but there are values that are pointless to use or have no visible effect.

All time durations are counted like “Value” * 8ms. Consequently, that means that the maximum TSD is $255 * 8\text{ms} = 2040\text{ms} = 2.04\text{s}$.

There are some rules and limits to consider:

- TSD value should be counted as minimum of $1 + N * (P\text{-ON} + P\text{-OFF})$. If TSD is equal or smaller than that value, the output will be continuously on with a short light dip at the end of the sequence.
- P-ON and P-OFF value should be bigger than 2 to have a visible effect. 8ms are difficult to notice and 0 means no effect. If P-ON = 0 than the output (LED) will be always off and if P-OFF = 0 than the output (LED) will be always on.
- P-ON is visible for 8ms if $N = 1$ and $TSD \geq 5$.



Figure 14

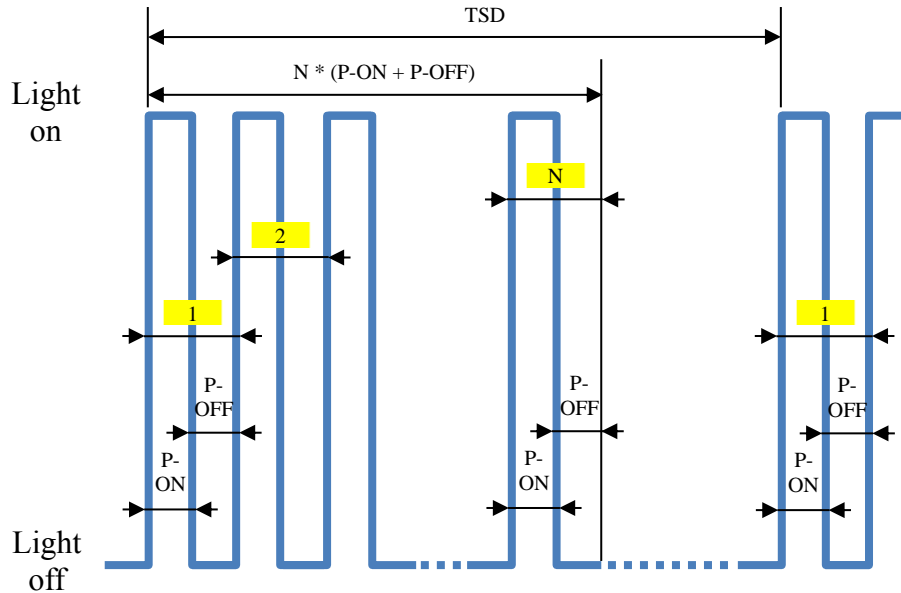

Figure 12 shows a diagram where $TSD > 1 + N * (P-ON + P-OFF)$ and $P-ON = P-OFF$



The values of P-ON and P-OFF can be independently configured as shown in Table 5 following the same rules described above.

When an effect is set up and turned on it will run in loop, as you can see in Figure 14, until it is turned off. Please notice that if $TSD > 1 + N * (P-ON + P-OFF)$ than after requested pulses are shot it will be a light off period until the next sequence starts over. If $TSD = 1 + N * (P-ON + P-OFF)$ than the new sequence will start at once after pulse N is over.

Effects 8÷13 needs only the TSD CV to be defined since the ON/OFF ratio is predefined. However, for the effects that have also ON/OFF fade effect, the light intensity value will affect the visual experience as described below.

For the effects 9, 11 and 13 the prescribed light intensity will affect the ON/OFF duration since there will be a delay between the ON command and the moment the LED will reach the prescribed light intensity and there will be a delay between the OFF command and the moment when the LED will be completely off. For a better understanding Figure 15 is illustrating the above behavior for effect 9 with different light intensity and fade-in/out settings.

In Figure 15 the effect 9 was chosen that means that the ON/OFF duration is 50% each. Since this effect has also fade-in/out that can have duration between 0 and 127 it means that we should consider that after 50% of the TSD the light will not be off but the fade-off will start with the prescribed value.



The current example is based on an TSD=255 with effect 9. This was chosen to make it easier since the TSD will have 255-time steps and the PWM value for 100% light intensity is at “step” 255.

So, if we make fade in (CV112) = 63, and we set the light intensity to 25 (10%), 127 (50%) and 255 (100%) we will have the response as in raising part of the green, orange and blue trace in Figure 15. What is to be noticed is that the maximum light intensity will be reached in different moments. Here is the reason of this: if the number of steps to reach the maximum prescribed light intensity (PWM) is smaller than the number of prescribed time steps (in this case for the green trace $CV123/139 = 25 < CV112 = 63$) than the maximum PWM will be reached earlier than the prescribed value in CV112. For the current example the green trace will reach the maximum PWM after 25 steps (the number of PWM steps will be equal with the number of time steps) that means 10% of TSD.

The orange and the blue trace have the maximum PWM value bigger than the number of time steps. Orange is 127 and blue is 255 and both must reach the maximum PWM in the prescribed value of CV122 = 63. This will happen since if CV112 value is smaller than the PWM value than the CV112 value will be followed and PWM will rise faster to reach the requested value in the defined timeframe. In this example for the orange trace PWM will rise two times faster and for the blue trace will rise 4 times faster. The dotted green lines are showing the path of a trace if the value of the PWM is equal with the value of CV112. All above explanations are valid also if for the descending part of the traces considering the value of CV113.

The green and the orange trace have the CV112 = CV113 = 63. The blue trace has the CV113 (fade-out) = 126 so it will reach 0 value of the PWM (light off) at the end of TSD.



Figure 15

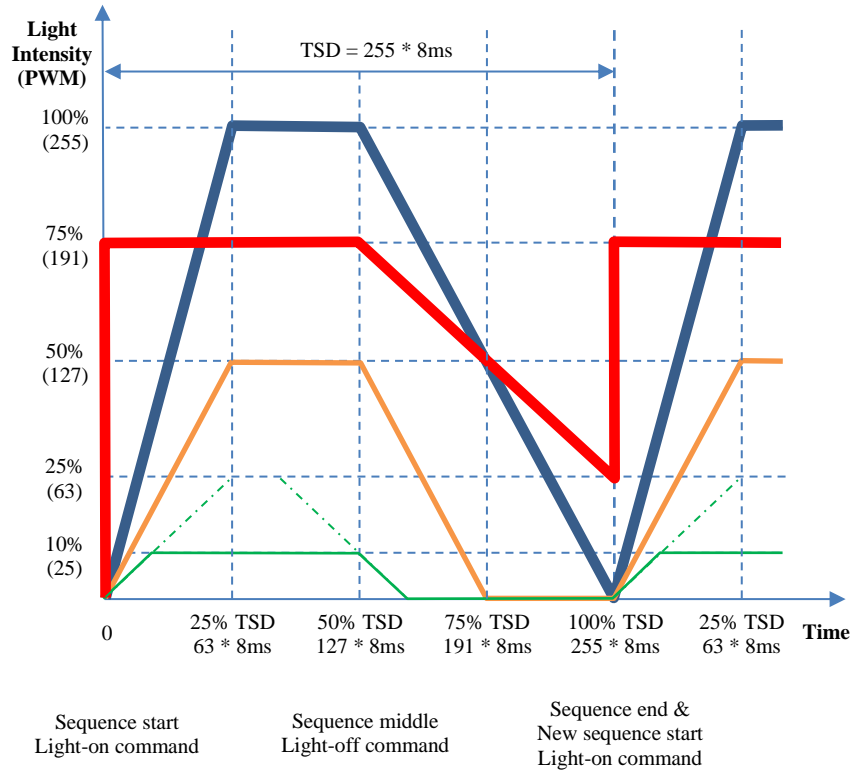



As you noticed the value of CV113 is set to 126 and not to 127 as anyone should expect. Setting CV112 and CV113 to 127 will have an exceptional result since having this value set in the two CVs the rise and fall speed will not be increase so PWM will change on step (up or down) / one time step. This is explained below and shown in Figure 15 by the red trace.

The red trace has the following settings: CV112 = 0, CV113 = 127, CV123/CV139 (PWM) = 191. The effect is still 9 and CV125/CV141 (TSD) = 255. With this setting this is what will happen: the light will turn on with no effect (PWM will switch to 191 instantly) and it will stay on at 75% of full PWM until the middle of the TSD when the dim will start. Since the PWM will make one step each time step of 8ms there will be not enough remaining steps to the end of the sequence so that the PWM will reach zero. To be more specific, at the end of the TSD, PWM will go down to 25% (63). The other way around, if CV112 = 127 and PWM is set to 255 (using the same effect settings as above) than PWM will never reach the maximum value, but it will reach the maximum of 127.

To make it short, the PWM will rise faster if the number of time steps is smaller than the number of PWM steps with one exception: if the value of time steps is 127 and the PWM steps number is >127 than PWM will change on step at one time step in both directions (up and down).



13. Multiple protocol operation (analog and digital operation)

The FD Micro Function Decoder can work in 2 different track environments: DCC and DC. When powered on the decoder will check if DCC signal is present on the track and execute the received commands. If DC voltage is present on the track for more than timeout period, the decoder will switch to analog mode and will turn on the functions configured in CV13 and CV14. The timeout period is set in CV11, and it is equal to CV11 decimal value * 8ms. The maximal value is 2,048s.

CV12, CV14, CV29 are influencing the decoder behavior related to protocols. The meaning of CV12 bits is described in Table 6: CV12. CV29 bit 2 will turn off the analog conversion if it is set to 0 so the Function Decoder will not switch to analog mode when digital communication is off.

CV13 and CV14 are responsible for the Function Decoder behavior in analog environment. The factory default value is CV14 = 3 and that means that forward and reverse lights are turned on in analog mode, according to the travel direction.

Table 6: CV12

CV12 bit	Value	Working mode (protocol)
0	0	DC mode OFF
	1	DC mode ON
2	0	DCC mode(protocol) OFF
	1	DCC mode(protocol) ON



For safety reasons, even if bit 0 of CV12 is set to 0 (DCC mode = OFF), CV12 can still be modified over DCC. The DCC programming commands are executed even if DCC digital mode is turned off.

If you want to activate other functions in analog DC mode, they must be defined in CV13 and CV14 and their Function Mapping must be defined as in in Function Mapping chapter.



Only functions F0, F1÷F14 can be turned on/off in analog DC mode.

14. Secondary address (decoder lock)

When using multiple decoders within the same housing (carriage or locomotive), it is useful to use a secondary address that will allow selecting a certain decoder. In this way each decoder can be programmed independently on the Programming Track without the need to remove it from the housing. The secondary addresses must be programmed in each decoder CV16 (LockID) before assembling it in the housing. The range for the secondary addresses is 1÷7 (0 means secondary addressing is disabled). So maximum 7 different decoders can be placed in the same housing.

In this case the programming commands will be accepted only by the decoder that has the stored CV16 value (LockID) matching the value written in CV15 (LockValue).



WARNING: CV16 can be programmed only if the correct value is programmed in CV15.



If Secondary Address is enabled ($CV16 \neq 0$), the only CV that accepts read/write is CV15. So, if the value of CV16 is not known, the only way to find it out is to write values from 1 to 7 in CV15 until the decoder will respond.

Assigning secondary addresses to each decoder before assembling them in the railcar (locomotive) or carriage sets allows individual decoder programming when the complete train is on the Programming Track (so only the decoder that has the same value in CV15 and CV16 will be programmed).



The decoder lock is useful also if you want to prevent accidental CV changes.



15. Bidirectional communication (RailCom)

RailCom is a system that allows two-way communication between a Command Station and a decoder. So, the decoder may send messages such as command confirmation receipt, address, actual speed, internal temperature, load, and other status information.

The RailCom operating principle is based on the introduction of short gaps (cutouts, max 500 μ s) by the Command Station at the end of each DCC packet where it interrupts the power supply and short-circuits the two lines. In these gaps the decoders will send a few bytes of data that are received by the RailCom detector connected between the locomotive and the Command Station or by the Command Station itself (if its capable to receive RailCom information).

The data packet is divided into two channels. In the first channel, the address (short, long, or consist) of the decoder is transmitted. In the second channel, CV handling POM responses are delivered (reading, writing result).

RailCom communication can be deactivated from CV29-Bit3 (0 - RailCom inactive, 1 - RailCom active). Channels 1 and 2 are enabled in CV28 Bit0 and Bit1. The automatic switch off channel 1 transmission can be enabled from bit2 of CV28.



16. Special functions

By using our special functions we can get information about:

- The internal temperature of the decoder
- The quality of the received DCC signal

CV223 contains the function number which activation will trigger the saving of the current values into the decoder non-volatile memory (EEPROM). Saving the instantaneous values is done by activating (turn ON and turn OFF) this function from the Command Station (or tOm Programmer).



Without activating the function number given in CV223 (turn On, then Off), the values in the corresponding CVs will not be updated!

The internal (saved) temperature of the decoder can be read from CV216 in Celsius degrees. In CV217 a temperature limit is set, which if it is exceeded, the decoder will stop working until the temperature drops below this limit.

The DCC Signal Quality Indicator (QoS = Quality of Signal) is stored in CV219 as percentage (in the range 0-100%). The lowest QoS value detected by the decoder from the last reading is written in CV218. Write 100 in CV218 to reset the default value (before reading, activate the save function set in CV223).



17. SUSI

The FD Micro Function Decoder has SUSI interface available on AUX3 (SUSI-CLK) and AUX4 (SUSI-DATA) logic level outputs. The interface is used for sound or function decoders. It is strongly recommended to use the standard wire colors as in General description of FD Micro decoders to avoid wrong connections.



Attention! Improper connection of the SUSI module may cause damage to the SUSI module

17.1. Programming SUSI modules

Like other digital decoders, SUSI decoders can be personalized by changing some operating parameters. The values of these parameters are stored in CV897 to CV1024. The SUSI decoders are programmed through the FD Micro decoder. Please refer to the SUSI decoder user manual before programming it.

The SUSI decoders CVs can be written either in PT or PoM mode. Because some digital systems allow writing and reading of CVs only up to CV255, a special mechanism for these digital systems has been implemented in the FD Micro decoder. Two CVs are dedicated providing access to the higher CV numbers of the SUSI decoders. CV97 is used as index, and CV98 is used as transport CV. The target SUSI decoder CV number is composed of the value of $CV97 + 800$. CV98 is the container of the value that is to be written or read to / from the $CV97 + 800$. Below are 2 examples of read/write procedure.



Examples:

- If you want to write value “1” in CV910 of the SUSI decoder, you must write “110” ($910 - 800 = 110$) in CV97 and value “1” in CV98. After entering value “1” in CV98, the FD Micro decoder will transmit a command on the SUSI interface to the SUSI decoder (sound or function decoder) to write the value “1” in CV910.
- If you want to read the content of CV 902 from the SUSI decoder that is connected to the FD Micro decoders SUSI interface, enter the value 102 ($902 - 800 = 102$) in CV97, and read the CV98 value. This value is equal to the value contained in CVC 902 of the SUSI decoder (sound or function decoder) connected to the FD Micro decoder.

Bit1 of CV118 will enable/disable the SUSI interface. The factory default setting is SUSI disabled (Bit1 of CV118 = “0”)



18. Using a power pack or external capacitors

It is very likely that the rails and locomotive wheels can become dirty because of dust, grease or other insulating substances that will interrupt the power to get to the decoder. In these cases, the locomotive will behave in an undesired way by slowing down then speed up again. When the locomotive is traveling with slow speed it can even stop because of the poor contact. To avoid this unwanted behavior buffer capacitors (220 μ F / 25V or for better results higher but not exceeding 2200 μ F) or uninterruptible power supplies (SPP) can be used.

Follow the instructions below for connecting a SPP or capacitor. The position of the contacts where the wires are (to be) attached are described below.



Installing these devices requires quality soldering equipment and experience. Our warranty does not cover defects due to inappropriate interventions and soldering

18.1. SPP (with supercapacitor)

The SPP modules allow FD Micro decoders to operate up to 4 seconds without DCC power from rails (depending on lights consumption and capacitor charge status). To connect the SPP modules, use the 3 soldering pads located as on the photo below. Please refer to SPP user manual for installation instruction. This duration is set in CV222, in steps of 16ms (default value 255, $CV_value * 16ms = 4$ seconds). After this period expired in the absence of the DCC signal, even if the SPP its not fully discharged, the decoder will disable all of the outputs. The functions will be resumed only after the DCC signal reappears.



Uninterruptible power supplies (SPP / Smart Power Packs or equivalent) allow both write and read of CVs in the traditional way without having to remove them. Switching off the SPP source during programming is done automatically by the FD Micro through the third wire (Charge).

To connect the SPP modules, use the 2 contacts located on one of the FD Micro left side, and one of the AUX3÷AUX6 outputs for the Charge wire, as can be seen in the picture below. Details of the connection can be found in the manual of the SPP (Theoretically the FL/RL can eb also configured for Charge Control, but the outputs will have inverted logic. We recommend this configuration only for expert users).

After deciding on which output will be used for the Charge connection to the SPP, the effect 5 must be used on that output (see Table 4 and Table 7:)

Figure 17: Connecting the SPP

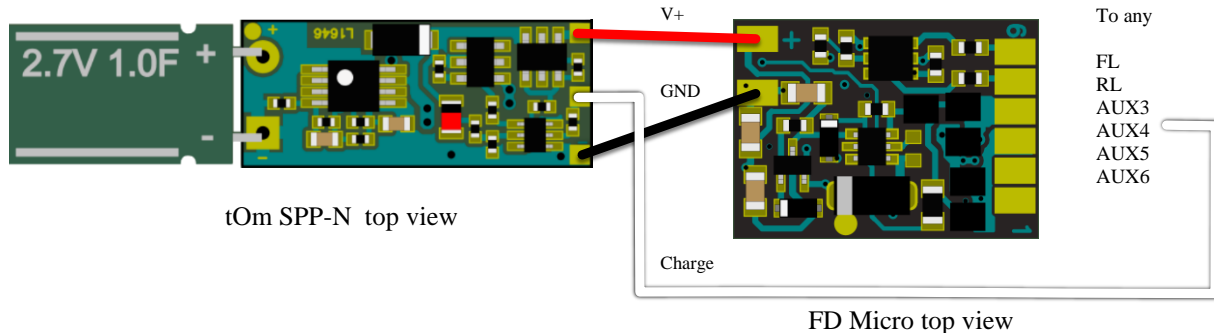



The uninterruptible power supply control is usable only in digital mode, in analog mode they are disabled (see CV29 configuration).

To avoid very high consumption when several SPP modules are used in the same setup it is strongly recommended to use a start delay (different values for each of the decoders). The delay can be set in CV221 in seconds and it represents the time after which the charging of the SPP module will started after the track is powered on. When multiple decoders are used on the same track, this time will have different values to avoid the simultaneous start-up of all SPPs.

18.2. Buffer capacitor

A simple buffer capacitor can be used instead of the SPP. Be aware that this will give way less extra power (depending of the size and amount of capacitors). However, expect fractions of a second.

When using buffer capacitors, a charging current resistor and a discharging diode are needed too (already integrated on the FD Micro circuit board).

It is recommended to use values in the range $220\mu\text{F} \div 2200\mu\text{F} / 25\text{V}$. The capacitor is not included in the FD Micro package.



The black wire will be soldered to the GND and the red one to the V+ as in the figure below. After making the connections, we can use a heat shrinkable tube or insulating tape for insulation.

Figure 18: Connecting the external capacitor

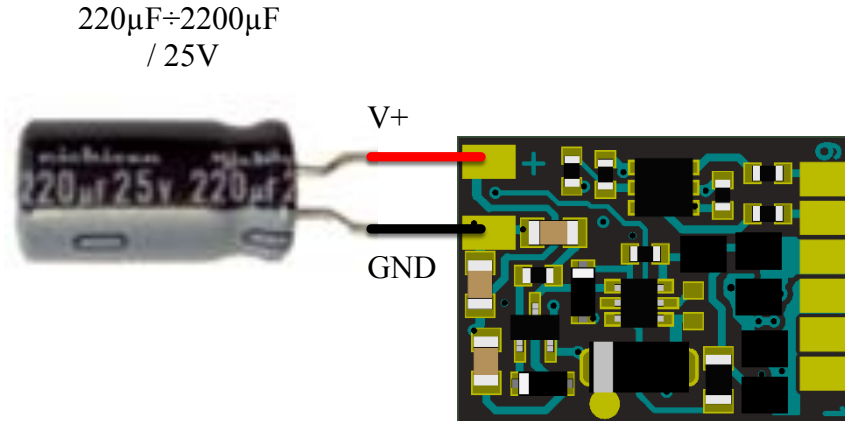

A high value buffer capacitor will prevent further CV operations on programming track or firmware updates. Programming CVs or updating firmware will be possible only after temporarily removing the buffer capacitor.



19. Firmware update

You can update FD Micro function decoder operating software (called firmware) any time. New firmware versions are used to eliminate errors (bugs) when operating decoders or to implement new functions.

The firmware update can be performed with the tOm Programmer without having to remove the decoder from the locomotive. **(Please note: if a buffer capacitor is connected to the decoder, this can prevent the firmware update. In this case de capacitor must be disconnected while performing the update sequence)**

The tOm Programmer's operating software and firmware upgrade files can be downloaded from the [train-O-matic website](#). For the firmware upgrade procedure, please refer to the tOm Programmer's user manual.

The current firmware version can be read from the following CVs:

CV253 Firmware version

CV254 Firmware subversion

CV254 Build version, upper byte

CV256 Build version, lower byte



20. User data

CV105 and CV106 are two CVs that can be used to store user identifiers (serial number, etc.). The particularity of these two CVs is that after a reset their contents will not be erased.

21. Other functions

The FD Micro can save the last function command received. This feature can be activated programming 1 in CV100. If this feature is activated than the decoder will turn on all the functions that were active before a power outage/interruption. This will happen even if the DCC command were not received to activate them. The functions F0 to F28 are saved by this feature.

The functions state, restored from the saved values, are overwritten by the first received DCC command belonging to the given function group.



22. Accessories

- tOm SPP can optionally be connected to a decoder and offers up to 4 seconds of energy independence
- The tOm programmer is a PC interface for programming DCC locomotive decoders
- Shine FDT, Shine LT, Shine MICRO are LED modules for lighting locomotives and wagons
- Shine mini/midi/maxi digi/ana are LED circuit boards for the interior lighting of wagons
- TD Maxi, TD Roco are switching decoders for turnouts

For details on accessories and a complete list of railroad products, visit the page:

www.train-o-matic.com

23. Technical support

If you have any questions or suggestions about train-o-matic products, you can write to us at:

support@train-o-matic.com



24. The decoder CV table

In the table below the columns are named as follows:

- "CV" column contains the configuration variable number
- "Default Value" column contains the "factory" value of the CVs (after a decoder reset, all CVs will have the appropriate value in this column)
- "Value Range" column contains the range of usable values for each CV
- "Description" column contains the name (if there is an established name) and information about the CV function.

Table 7: CV table

CV	Default value	Value range	Description
1	3	0÷127	Decoder Address Short, 7 bits
7	2	-	Software Version (only readable)
8	78	-	Manufactured ID/RESET (readable 78 = train-O-matic, any written value will reset the decoder to the factory default values)
11	25	0-255	Packet time-out value = CV11 * 8ms (default time = 200ms)
12	5	0-255	Power source conversion, DCC and DC mode enabled



FD Micro Function Decoder

User Manual for FW 1.2.28

Version 0.0.10

CV	Default value	Value range	Description
13	0	0÷255	Analog Mode, Alternate Mode Function Status F1 ÷ F8 Bit 0 = 0(0): F1 not active in Analog mode = 1(1): F1 active in Analog mode Bit 1 = 0(0): F2 not active in Analog mode = 1(2): F2 active in Analog mode Bit 2 = 0(0): F3 not active in Analog mode = 1(4): F3 active in Analog mode Bit 3 = 0(0): F4 not active in Analog mode = 1(8): F4 active in Analog mode Bit 4 = 0(0): F5 not active in Analog mode = 1(16): F5 active in Analog mode Bit 5 = 0(0): F6 not active in Analog mode = 1(32): F6 active in Analog mode Bit 6 = 0(0): F7 not active in Analog mode = 1(64) F7 active in Analog mode Bit 7 = 0(0): F8 not active in Analog mode = 1(255): F8 active in Analog mode



FD Micro Function Decoder

User Manual for FW 1.2.28

Version 0.0.10

CV	Default value	Value range	Description
14	1 = 1	0÷255	Analog Mode, Alternate Mode Function. Status F0f, F0r, F9 ÷ F14, Bit 0 = 0(0): F0 forward not active in Analog mode = 1(1): F0 forward active in Analog mode Bit 1 = 0(0): F0 revers not active in Analog mode = 1(2): F0 revers active in Analog mode Bit 2 = 0(0): F9 not active in Analog mode = 1(4): F9 active in Analog mode Bit 3 = 0(0): F10 not active in Analog mode = 1(8): F10 active in Analog mode Bit 4 = 0(0): F11 not active in Analog mode = 1(16): F11 active in Analog mode Bit 5 = 0(0): F12 not active in Analog mode = 1(32): F12 active in Analog mode Bit 6 = 0(0): F13 not active in Analog mode = 1(64) F13 active in Analog mode Bit 7 = 0(0): F14 not active in Analog mode = 1(255): F14 active in Analog mode



FD Micro Function Decoder

User Manual for FW 1.2.28

Version 0.0.10

CV	Default value	Value range	Description
15	0	0÷7	LockValue: Enter the value to match Lock ID in CV16 to unlock CV programming. No action and no ACK will be performed by the decoder when LockValue is different than LockID. In this situation only CV15 write is allowed.
16	0	0÷7	LockID: To prevent accidental programming use unique ID number for decoders with same address (0÷7) like 1-loco decoder, 2-sound decoder, 3-Function Decoder, ...
17	192	192÷255	Extended Address, Address High
18	3	0÷255	Extended Address, Address Low
19	0	0÷127	Consist Address If CV19 > 0: Speed and direction is governed by this consist address (not the individual address in CV #1 or #17+18); functions are controlled by either the consist address or individual address, see CV21 & CV22.



FD Micro Function Decoder

User Manual for FW 1.2.28

Version 0.0.10

CV	Default value	Value range	Description
21	0	0÷255	Functions defined here will be controlled by the consist address. Bit 0 = 0(0): F1 controlled by individual address = 1(1): by consist address Bit 1 = 0(0): F2 controlled by individual address = 1(2): by consist address Bit 2 = 0(0): F3 controlled by individual address = 1(4): by consist address Bit 3 = 0(0): F4 controlled by individual address = 1(8): by consist address Bit 4 = 0(0): F5 controlled by individual address = 1(16): by consist address Bit 5 = 0(0): F6 controlled by individual address = 1(32): by consist address Bit 6 = 0(0): F7 controlled by individual address = 1(64): by consist address Bit 7 = 0(0): F8 controlled by individual address = 1(255): by consist address



FD Micro Function Decoder

User Manual for FW 1.2.28

Version 0.0.10

CV	Default value	Value range	Description
22	3	0-63	Functions defined here will be controlled by the consist address. Bit 0 = 0(0): F0 (forward) controlled by individual address = 1(1): by consist address Bit 1 = 0 (0): F0 (reverse) controlled by individual address = 1(2): by consist address Bit 2 = 0(0): F9 controlled by individual address = 1(4): by consist address Bit 3 = 0(0): F10 controlled by individual address = 1(8): by consist address Bit 4 = 0(0): F11 controlled by individual address = 1(16): by consist address Bit 5 = 0(0): F12 controlled by individual address = 1(32): by consist address



FD Micro Function Decoder

User Manual for FW 1.2.28

Version 0.0.10

CV	Default value	Value range	Description
28	3	0÷7	RailCom configuration Bit 0 = 0(0): CH1 Address Broadcast Off = 1(1): CH1 Address Broadcast On Bit 1 = 0(0): CH2 Data Transmission Off = 1(2): CH2 Data Transmission On Bit 2 = 0(0): CH1 Dynamic mode Off = 1(2): CH1 Dynamic mode On



FD Micro Function Decoder

User Manual for FW 1.2.28

Version 0.0.10

CV	Default value	Value range	Description
29	14 = 2 + 4 + 8	0-63	Configuration Data Bit 0 = 0(0): Locomotive Direction normal = 1(1): Locomotive Direction reversed Bit 1 = 0(0): FL controlled by bit 4 in Speed and Direction instructions = 1(2): FL controlled by bit 4 in Function Group One instruction ¹ Bit 2 = 0(0): Power Source Conversion NMRA Digital Only (only DCC) = 1(4): Power Source Conversion Enabled (DC + DCC) Bit 3 = 0(0): Bi-Directional Communications disabled = 1(8): Bi-Directional Communications enabled Bit 4 – Not Used Bit 5 = 0(0): One byte addressing (short addressing) = 1(32): Two bytes addressing (extended/long addressing) Bit 6 – Not Used Bit 7 – Not Used

¹ See [NMRA S-9.2.1](#)



FD Micro Function Decoder

User Manual for FW 1.2.28

Version 0.0.10

CV	Default value	Value range	Description
33	1	0÷255	F0, Forward move mapping Bit 0 = 0(0): FL not active on F0 forward = 1(1): FL active on F0 forward Bit 1 = 0(0): RL not active on F0 forward = 1(2): RL active on F0 forward Bit 2 = 0(0): AUX3 not active on F0 forward = 1(4): AUX3 active on F0 forward Bit 3 = 0(0): AUX4 not active on F0 forward = 1(8): AUX4 active on F0 forward Bit 4 = 0(0): AUX5 not active on F0 forward = 1(16):AUX5 active on F0 forward Bit 5 = 0(0): AUX6 not active on F0 forward = 1(32):AUX6 active on F0 forward



FD Micro Function Decoder

User Manual for FW 1.2.28

Version 0.0.10

CV	Default value	Value range	Description
34	2	0÷255	F0, backward move mapping Bit 0 = 0(0): FL not active on F0 backward = 1(1): FL active on F0 backward Bit 1 = 0(0): RL not active on F0 backward = 1(2): RL active on F0 backward Bit 2 = 0(0): AUX3 not active on F0 backward = 1(4): AUX3 active on F0 backward Bit 3 = 0(0): AUX4 not active on F0 backward = 1(8): AUX4 active on F0 backward Bit 4 = 0(0): AUX5 not active on F0 backward = 1(16):AUX5 active on F0 backward Bit 5 = 0(0): AUX6 not active on F0 backward = 1(32):AUX6 active on F0 backward



FD Micro Function Decoder

User Manual for FW 1.2.28

Version 0.0.10

CV	Default value	Value range	Description
35	1	0÷255	F1 mapping Bit 0 = 0(0): FL not activated with F1 = 1(1): FL activated with F1 Bit 1 = 0(0): RL not activated with F1 = 1(2): RL activated with F1 Bit 2 = 0(0): AUX3 not activated with F1 = 1(4): AUX3 activated with F1 Bit 3 = 0(0): AUX4 not activated with F1 = 1(8): AUX4 activated with F1 Bit 4 = 0(0): AUX5 not activated with F1 = 1(16):AUX5 activated with F1 Bit 5 = 0(0): AUX6 not activated with F1 = 1(32):AUX6 activated with F1
36	2	0÷255	F2 mapping, same bit meaning with CV35
37	4	0÷255	F3 mapping, same bit meaning with CV35
38	8	0÷255	F4 mapping, same bit meaning with CV35
39	16	0÷255	F5 mapping, same bit meaning with CV35
40	32	0÷255	F6 mapping, same bit meaning with CV35
41	0	0÷255	F7 mapping, same bit meaning with CV35



FD Micro Function Decoder

User Manual for FW 1.2.28

Version 0.0.10

CV	Default value	Value range	Description
42	0	0÷255	F8 mapping, same bit meaning with CV35
43	0	0÷255	F9 mapping, same bit meaning with CV35
44	0	0÷255	F10 mapping, same bit meaning with CV35
45	0	0÷255	F11 mapping, same bit meaning with CV35
46	0	0÷255	F12 mapping, same bit meaning with CV35
47	0	0÷255	F13 mapping, same bit meaning with CV35
48	0	0÷255	F14 mapping, same bit meaning with CV35
49	0	0÷255	F15 mapping, same bit meaning with CV35
50	0	0÷255	F16 mapping, same bit meaning with CV35
51	0	0÷255	F17 mapping, same bit meaning with CV35
52	0	0÷255	F18 mapping, same bit meaning with CV35
53	0	0÷255	F19 mapping, same bit meaning with CV35
54	0	0÷255	F20 mapping, same bit meaning with CV35
55	0	0÷255	F21 mapping, same bit meaning with CV35
56	0	0÷255	F22 mapping, same bit meaning with CV35
57	0	0÷255	F23 mapping, same bit meaning with CV35
58	0	0÷255	F24 mapping, same bit meaning with CV35
59	0	0÷255	F25 mapping, same bit meaning with CV35
60	0	0÷255	F26 mapping, same bit meaning with CV35



FD Micro Function Decoder

User Manual for FW 1.2.28

Version 0.0.10

CV	Default value	Value range	Description
61	0	0÷255	F27 mapping, same bit meaning with CV35
62	0	0÷255	F28 mapping, same bit meaning with CV35
96	1	1, 6	Output mapping mode: 1 – NMRA (CV33 ÷ CV62) 6 – extended mapping (CV120 ÷ CV215)
97	100		SUSI CV transport. SUSI CV = 800 + CV97value (default CV900)
98	-		SUSI DATA transport. Accessing CV = 800 + CV97
100	0	0÷1	Enable saving last functions state: 0 – disabled; 1 - enabled
101	0	0÷255	Last saved function state F0, F1-F4
102	0	0÷255	Last saved function state F5-F12
103	0	0÷255	Last saved function state F13-F20
104	0	0÷255	Last saved function state F21-F28
105	0	0÷255	User data (not affected by decoder reset)
106	0	0÷255	User data (not affected by decoder reset)
112	25	1÷127	FadeIN Light Effect delay, in 8ms steps (default 200ms)
113	15	1÷127	FadeOUT Light Effect delay, in 8ms steps (default 120ms)
114	3	0÷7	Fluorescent Tube Start, Blinking Delay 1-÷8 delay step [0 ÷ 7]
115	10	1÷255	Random Time Period, 1s ÷ 255s
116	3	0÷7	Flicker Period: Fast-Slow 0 ÷ 7



FD Micro Function Decoder

User Manual for FW 1.2.28

Version 0.0.10

CV	Default value	Value range	Description
117	3	0÷7	Defective Neon effects repetition time, 0 fast repetition, 7 slow repetition
118	64	0÷255	Second configuration CV Bit 0 = 0(0): AUX3/AUX4 logical level outputs = 1(1): AUX3/AUX4 SUSI outputs Bit 6 = 0(0): FL/RL output signaling during boot-load operation = 1(64): FL/RL disabled during boot-load operation
120	64	0÷255	First function number which turn on FL
121	1	0÷255	Second function number which turn on FL
122	63	0÷255	Function number which must be turned off so FL can be turned on
123	255	0÷255	FL Light intensity (PWM) (see Table 4)
124	1	0÷255	FL Effect (see Table 4)
125	127	0÷255	FL Blink period (Bp), in 8ms steps, max: 2s, $Bp > n * (Bpl + Bpp)$ (see Table 4)
126	2	0÷255	FL Blink pulse length (Bpl), in 8ms steps, max: 2s
127	12	0÷255	FL Blink pause length (Bpp), in 8ms steps, max: 2s
128	3	0÷255	FL Blink repetition time (n)
129	0	0÷255	FL Turn ON delay
130	0	0÷255	FL Turn OFF delay
131	255	0÷255	reserved
132	255	0÷255	reserved



FD Micro Function Decoder

User Manual for FW 1.2.28

Version 0.0.10

CV	Default value	Value range	Description
133	255	0÷255	reserved
134	255	0÷255	reserved
135	255	0÷255	reserved
136	128	0÷255	First function number which turn on RL
137	2	0÷255	Second function number which turn on RL
138	63	0÷255	Function number which must be turned off so RL can be turned on
139	255	0÷255	RL Light intensity (PWM)
140	1	0÷255	RL Effect
141	127	0÷255	RL Blink period (Bp), in 8ms steps, max: 2s, $Bp > n * (Bpl + Bpp)$
142	2	0÷255	RL Blink pulse length (Bpl), in 8ms steps, max: 2s
143	12	0÷255	RL Blink pause length (Bpp), in 8ms steps, max: 2s
144	3	0÷255	RL Blink repetition time (n)
145	0	0÷255	RL Turn ON delay
146	0	0÷255	RL Turn OFF delay
147	255	0÷255	reserved
148	255	0÷255	reserved
149	255	0÷255	reserved
150	255	0÷255	reserved
151	255	0÷255	reserved



FD Micro Function Decoder

User Manual for FW 1.2.28

Version 0.0.10

CV	Default value	Value range	Description
152	3	0÷255	First function number which turn on AUX3
153	63	0÷255	Second function number which turn on AUX3
154	63	0÷255	Function number which must be turned off so AUX3 can be turned on
155	255	0÷255	AUX3 Light intensity (PWM)
156	1	0÷255	AUX3 Effect
157	127	0÷255	AUX3 Blink period (Bp), in 8ms steps, max: 2s, $Bp > n * (Bpl + Bpp)$
158	2	0÷255	AUX3 Blink pulse length (Bpl), in 8ms steps, max: 2s
159	12	0÷255	AUX3 Blink pause length (Bpp), in 8ms steps, max: 2s
160	3	0÷255	AUX3 Blink repetition time (n)
161	0	0÷255	AUX3 Turn ON delay
162	0	0÷255	AUX3 Turn OFF delay
163	255	0÷255	reserved
164	255	0÷255	reserved
165	255	0÷255	reserved
166	255	0÷255	reserved
167	255	0÷255	reserved
168	4	0÷255	First function number which turn on AUX4
169	63	0÷255	Second function number which turn on AUX4
170	63	0÷255	Function number which must be turned off so AUX4 can be turned on



FD Micro Function Decoder

User Manual for FW 1.2.28

Version 0.0.10

CV	Default value	Value range	Description
171	255	0÷255	AUX4 Light intensity (PWM)
172	1	0÷255	AUX4 Effect
173	127	0÷255	AUX4 Blink period (Bp), in 8ms steps, max: 2s, $Bp > n * (Bpl + Bpp)$
174	2	0÷255	AUX4 Blink pulse length (Bpl), in 8ms steps, max: 2s
175	12	0÷255	AUX4 Blink pause length (Bpp), in 8ms steps, max: 2s
176	3	0÷255	AUX4 Blink repetition time (n)
177	0	0÷255	AUX4 Turn ON delay
178	0	0÷255	AUX4 Turn OFF delay
179	255	0÷255	Reserved
180	255	0÷255	Reserved
181	255	0÷255	Reserved
182	255	0÷255	Reserved
183	255	0÷255	Reserved
184	5	0÷255	First function number which turn on AUX5
185	63	0÷255	Second function number which turn on AUX5
186	63	0÷255	Function number which must be turned off so AUX5 can be turned on
187	255	0÷255	AUX5 Light intensity (PWM)
188	1	0÷255	AUX5 Effect
189	127	0÷255	AUX5 Blink period (Bp), in 8ms steps, max: 2s, $Bp > n * (Bpl + Bpp)$



FD Micro Function Decoder

User Manual for FW 1.2.28

Version 0.0.10

CV	Default value	Value range	Description
190	2	0÷255	AUX5 Blink pulse length (Bpl), in 8ms steps, max: 2s
191	12	0÷255	AUX5 Blink pause length (Bpp), in 8ms steps, max: 2s
192	3	0÷255	AUX5 Blink repetition time (n)
193	0	0÷255	AUX5 Turn ON delay
194	0	0÷255	AUX5 Turn OFF delay
195	255	0÷255	reserved
196	255	0÷255	reserved
197	255	0÷255	reserved
198	255	0÷255	reserved
199	255	0÷255	reserved
200	6	0÷255	First function number which turn on AUX6
201	63	0÷255	Second function number which turn on AUX6
202	63	0÷255	Function number which must be turned off so AUX6 can be turned on
203	255	0÷255	AUX6 Light intensity (PWM)
204	1	0÷255	AUX6 Effect
205	127	0÷255	AUX6 Blink period (Bp), in 8ms steps, max: 2s, $Bp > n * (Bpl + Bpp)$
206	2	0÷255	AUX6 Blink pulse length (Bpl), in 8ms steps, max: 2s
207	12	0÷255	AUX6 Blink pause length (Bpp), in 8ms steps, max: 2s
208	3	0÷255	AUX6 Blink repetition time (n)



FD Micro Function Decoder

User Manual for FW 1.2.28

Version 0.0.10

CV	Default value	Value range	Description
209	0	0÷255	AUX6 Turn ON delay
210	0	0÷255	AUX6 Turn OFF delay
211	255	0÷255	reserved
212	255	0÷255	reserved
213	255	0÷255	reserved
214	255	0÷255	reserved
215	255	0÷255	reserved
216	-	0÷255	Chip temperature read out. Before the readout function set in CV223 must be switched On and Off
217	100	0÷255	Temperature protection triggering threshold. Default value is 100°C
218	-	0÷100	Worst QoS (Quality of Service) value, saved by activating then deactivating function set in CV223. Read only
219	-	0÷100	QoS (Quality of Service) current value, saved activating then deactivating function set in CV223. Read only
220	0	0÷255	Reserved
221	2	0÷255	SPP (Smart Power Pack) start delay in seconds, default 2s
222	255	0÷255	SPP (Smart Power Pack) Timeout=16ms * Value. Ex: 16ms * 16 = 256ms. Default value = 4.08s



FD Micro Function Decoder

User Manual for FW 1.2.28

Version 0.0.10

CV	Default value	Value range	Description
223	28	0÷255	Function number which enables saving of QoS and Temperature value in CV216 ÷ CV219



FD Micro Function Decoder

User Manual for FW 1.2.28

Version 0.0.10

Copyright © 2023 Tehnologistic Ltd.
All rights reserved

The information in this document is subject to change without notice



“train-o-matic” and the logo are registered trademarks of Tehnologistic Ltd.

www.train-o-matic.com
www.tehnologistic.ro

Tehnologistic Ltd.
Str. Libertatii Nr. 35A
407035 Apahida, Cluj
Romania
Tel +40-264-556454
Fax +40-264-441275

